

Nov. 21, 1950

J. L. ENTWISTLE
MACHINE FOR APPLYING PRESSURE SENSITIVE
TAPE TO CONDUCTORS

2,530,655

Filed April 4, 1946

3 Sheets-Sheet 1

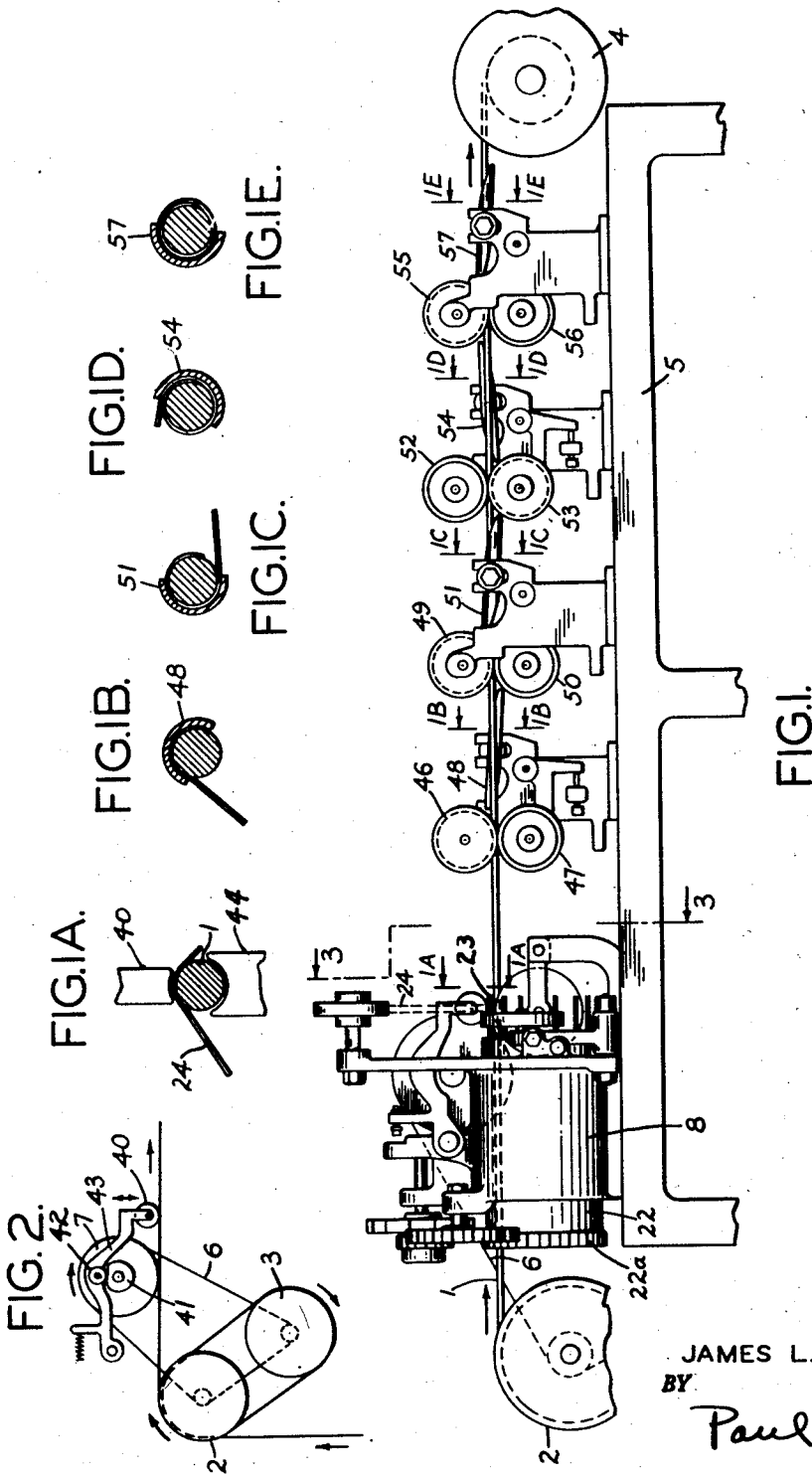

FIG. 2.

FIG. 1A.

FIG. 1B.

FIG. 1D.

FIG. 1C.

FIG. 1E.

FIG. 1.

INVENTOR.
JAMES L. ENTWISTLE
BY
Paul Kolisch
ATTORNEY

Nov. 21, 1950

J. L. ENTWISTLE
MACHINE FOR APPLYING PRESSURE SENSITIVE
TAPE TO CONDUCTORS

2,530,655

Filed April 4, 1946

3 Sheets-Sheet 2

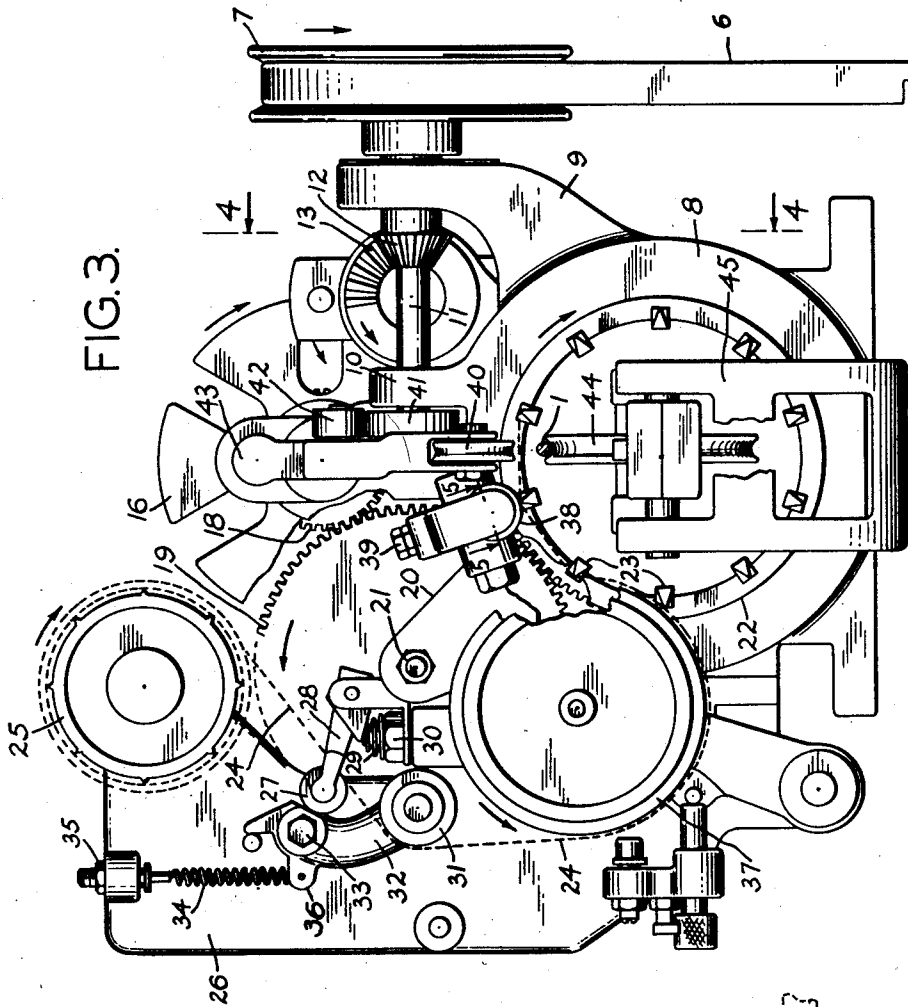

FIG. 4.

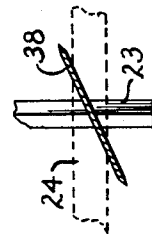
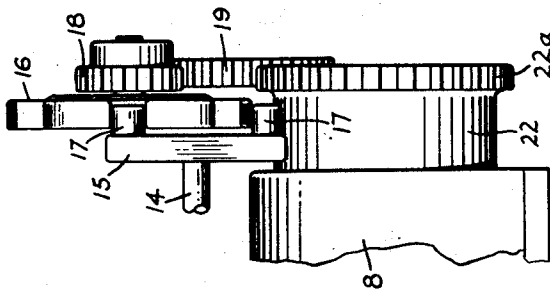

FIG. 5.

INVENTOR.
JAMES L. ENTWISTLE
BY *Paul Kolisch*
ATTORNEY

Nov. 21, 1950

J. L. ENTWISTLE
MACHINE FOR APPLYING PRESSURE SENSITIVE
TAPE TO CONDUCTORS

2,530,655

Filed April 4, 1946

3 Sheets-Sheet 3

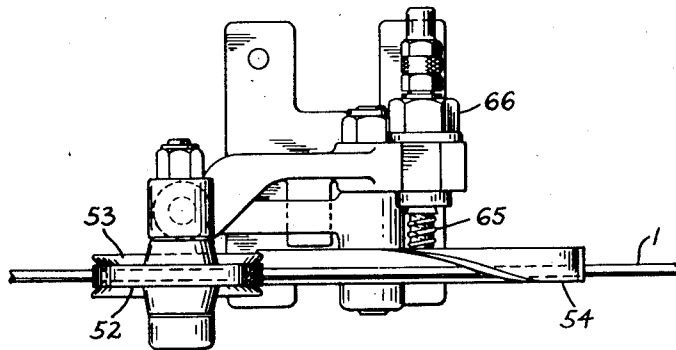

FIG. 6.

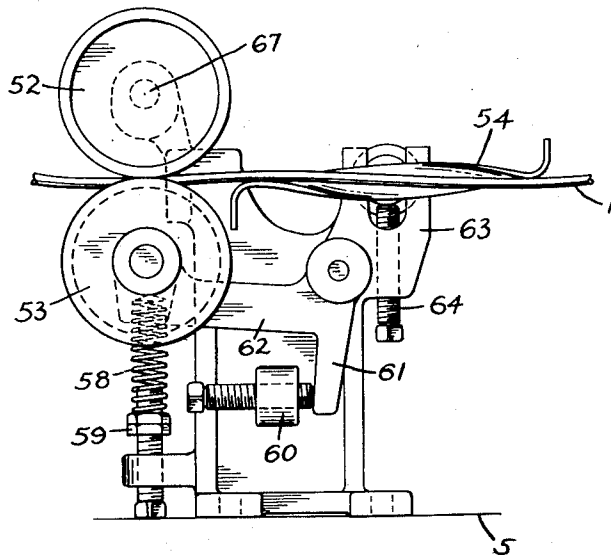

FIG. 7.

INVENTOR.
JAMES L. ENTWISTLE
BY *Paul Kolisch*
ATTORNEY

UNITED STATES PATENT OFFICE

2,530,655

MACHINE FOR APPLYING PRESSURE SENSITIVE TAPE TO CONDUCTORS

James L. Entwistle, Cranston, R. I., assignor to James L. Entwistle Co., Pawtucket, R. I., a partnership consisting of Margherita C. Entwistle and James L. Entwistle

Application April 4, 1946, Serial No. 659,634

9 Claims. (Cl. 216—29)

1

This invention relates to new and useful improvements in labeling machines and particularly in labeling machines for electric cords, cables, wires and the like, which hereinafter will be referred to by the general name of "conductor."

In order to identify the manufacturer and to certify successful testing of conductors, it is desirable to apply suitable labels at predetermined points on the conductor. The labels now used for this purpose are on a metallic backing which is cut into suitable lengths and bent around the finished conductor, e. g. one label for every five feet of conductor. Such labels may drop off during handling of the conductors; their initial cost and application are expensive; they cannot be applied during the process of manufacturing the conductor; and ragged edges that are likely to be formed in the metal backing often injure insulation provided around the conductor.

The object of the present invention is a machine and a method for labeling conductors at predetermined points during any stage of the process of manufacture without injuring the insulation or slowing down the manufacturing process. The labels applied according to the present invention cannot accidentally fall off and they will not be in the way when the finished conductor is packaged.

With these objects in view, the symbols of the label are printed or otherwise applied to successive lengths of a tape or web of suitable width. The tape has one surface coated with normally tacky, pressure-sensitive adhesive. Such tape when wound into a coil pulls off clean. Preferably, though not necessarily, the tape is opaque.

As the tape is pulled off the coil, a length containing the symbols representing one label is severed and pressed with its tacky side against the conductor so that parts of the label protrude therefrom. The conductor travels longitudinally through the machine and the protruding parts of the label are pressed or wiped around it so as to form a sleeve which encircles the conductor once or even several times. On large diameter conductors the label may not reach all around to form a complete sleeve.

The forming of the label around the conductor is preferably accomplished by a plurality of spiral wipers. These are sections of a metal strip so shaped and mounted as to press the protruding portion of the label uniformly against the traveling conductor. The wipers are so arranged that one or more wipe one protruding portion of the label in one direction and one or more wipe the

2

other protruding portion of the label in the other direction around the conductor.

According to one feature of the invention, the tape is unwound from a roll and carried into position by a series of evenly spaced rotating knives. When in position, one label is severed from the tape by the pressure of a cylinder against a knife, and a grooved roller pushes the label clear of the knives onto the conductor.

These and other features of the invention will more clearly appear from the appended claims, the following detailed description and the drawings, in which:

Fig. 1 is an elevated side view of the machine;

Fig. 1a is a transverse section showing a label immediately after being applied to the conductor;

Fig. 1b is a transverse section of the first stage of wiping the label;

Fig. 1c is a transverse section of the second stage of wiping the label;

Fig. 1d is a transverse section of the third stage of wiping the label;

Fig. 1e is a transverse section of the fourth stage of wiping the label;

Fig. 2 is a diagram showing the conductor driving the pulleys and the cam action which deposits the labels;

Fig. 3 is a transverse section on the lines 3—3 of Fig. 1;

Fig. 4 is a section on lines 4—4 of Fig. 3;

Fig. 5 is a plan view on the lines 5—5 of Fig. 3 of a detail of the label severing device;

Fig. 6 is a plan view of the third wiping unit; and

Fig. 7 is a front elevation of the third wiping unit.

A conductor 1 is pulled longitudinally over pulleys 2 and 3 through the machine by means of a power driven drum 4 on which the conductor 1 is wound. The machine rests on a table 5 carrying at one end the pulleys 2 and 3 which rotate in the direction of the arrows (Fig. 2) and drive through a belt 6 another pulley 7. Conductor 1 runs from one groove of pulley 2 around pulley 3 and then through a second groove of pulley 2 before entering one end of the machine.

The left hand portion of the machine (Fig. 1) comprises a large cylindrical casting 8 having several brackets. It is in this portion of the machine that the labels are applied to conductor 1 or to any other like object. Although the machine will be described as applying labels to a conductor it should be understood that the machine, especially the left hand portion, may be used to apply labels to many objects other than

3

conductors. A shaft 11 (Fig. 3) is journaled in brackets 9 and 10 (Fig. 3) of casting 8 and carries at one end pulley 7, through which it is rotated in the direction of the arrow (Fig. 3). A beveled gear 12 carried on shaft 11 meshes with crown gear 13 mounted on one end of shaft 14 (Fig. 4). At its other end (Fig. 4), shaft 14 carries a gear 15 which rotates a Geneva gear 16 by means of projections 17 in the direction of the arrow (Fig. 3). The intermittent rotary movement of Geneva gear 16 is transmitted to small gear 18 mounted on the same shaft as gear 16 but on the other side of 16 from that engaged by projections 17. Gear 18 meshes with a larger gear 19 which is mounted on shaft 21 journaled in a bracket 20 of the casting 8. Gear 19 engages gear teeth 22a formed in one end of larger cylinder 22 through which conductor 1 passes as it leaves pulley 2.

Large cylinder 22 rotates in casting 8 in the direction of the arrow (Fig. 3) and its right-hand end (Fig. 1) projecting from casting 8 carries a plurality of evenly spaced knives 23. While the elements 23 will be referred to as knives, they are, as will clearly appear from the description of the operation, not used to cut lengths of label in the manner usually associated with knives. The knives 23 are merely edges against which the label is borne so as to insure the severing thereof by pressure of a hard-surfaced cylinder 38. The space between knives 23 is equal to the length of one label to be applied to conductor 1. The blades of the knives 23 are triangularly shaped and sufficiently long with respect to the width of the tape so that the tape will not overhang the knives.

The labels are printed on a web or tape 24 which is fed from a roll 25 supported above the machine on an arm 26 extending from the casting 8. The tape is preferably made of cellulose acetate having a pressure sensitive adhesive coating. As it is pulled off the roll 25 it first engages a small roller 27 attached to a pivoted arm 28 which is pressed upward by a spring 29. Nut 30 is provided to adjust the tension of spring 29.

The tape 24 next engages with its slick side a roller 31 mounted on the free end of rocker arm 32 which is pivotally mounted at 33 on the bracket 26. A spring 34, which is adjustable by a nut 35, is stretched between the arm 26 and a lug 36 near the pivot point of the rocker 32 to press the roller 31 against the tape 24.

The rollers 27 and 31 will keep the unwound tape 24 taut and, should the tape break, the arms 28 and 32 will be moved by their springs 29 and 34 into a position in which they will effect the stopping of the machine in a manner not illustrated in detail in the drawing but well understood by those skilled in the art.

From the roller 31 the tape passes over the resilient surface of a relatively large roller 37. The tacky outside surface of the tape 24, as it lies on roller 37, is engaged by the knives 23 as the cylinder 22 rotates. The roller 37 is so mounted on a bracket of the casting 8 that it will be rotated counterclockwise (Fig. 3) when a knife 23 engages the tape 24 along the surface of roller 37. Thus, the tape is pulled off the supply roll 25.

The knives 23 do not sever the tape 24 when they engage it on the resilient surface of the roller 37 but carry the tape with them as the tape moves off the surface of roller 37, because the tacky side of the tape adheres to the edges of the knife blades. When a knife 23 arrives

4

with the adhering tape under a short, hard-surfaced cylinder 38, which is rotatably mounted in a bracket of the casting, the tape will be severed by being pressed firmly against cylinder 38. The cylinder 38 must be long enough to accommodate any width tape which is likely to be pressed against it. A nut 39 is provided to adjust the positioning of the cylinder 38 with respect to the knives 23.

The cylinder 38 is spring mounted so as to insure firm contact between the tape and contacting knife surface. As shown in Fig. 5 severing of the labels is further insured by the fact that the longitudinal axis of the cylindrical roller 38 is not parallel with the top edge of any knife 23 that happens to engage the tape 24 bearing against the cylinder 38. The cylinder 38 will make only successive point contacts with various points of the knife edge, insuring the severing of the tape that happens to be between the contacting points of the cylinder and the knife. Thus, the severing of the tape along a line, which for all practical purposes may be considered straight, will be insured. If the axis of the cylinder were parallel with the contacting edges of the knives, then when a knife 23 was brought into contact with the cylinder 38, the tape throughout its width would be suddenly engaged between the knife and the cylinder, and this in turn would permit the severing of the tape only if the surface of cylinder 38 and the bearing edge of the knife 23 were perfectly parallel throughout and engaged at the same pressure the tape throughout its width. In practice, it is impossible to attain this since either the cylinder or the knife or the thickness of the tape is subject to sufficient variations so that portions of the tape would not be engaged at all, or would not be engaged at the same pressure at which other portions were engaged, whereby the severing of the tape throughout its complete width would be impossible.

The severed end of the tape 24 extending between two adjacent blades 23 and adhering to both blades lies between conductor 1 and a grooved roller 40 aligned therewith. The label-cutting machine is so geared that as the label end is severed, the roller 40 pushes it against the transversely running conductor 1, causing it to adhere to its upper surface. The position of the label on the conductor 1 immediately after its application thereto is shown in Fig. 1a.

The rocking of the roller 40 is timed with the machine through the agency of a cam 41 (Fig. 2) mounted on one end of shaft 11 and engaging a roller 42 on rocker arm 43 which carries the grooved roller 40.

In order to insure proper adhesion of the label to the conductor 1, the conductor travels below the roller 40 on a sheave 44 carried by a bracket 45 of casting 8. The sheave 44 is also adjustably mounted so as to accommodate wires 1 of varying diameters and to insure their firm gripping between the sheave 44 and the roller 40. Also, both the sheave 44 and the roller 40 are adjustable sideways so as to insure that the short end of the label that protrudes from the wire will be of such length as to be fully wiped against the wire by the first wiper 48 which it engages during its further travel.

The roller 40 is arranged to push the label against the conductor 1 so that there will be a short and long end transversely projecting from the conductor. These projecting ends are then curved around the conductor to form the label

5

into a closed sleeve. This is accomplished by four pressing and wiping units whose structure will now be explained with the aid of Figs. 1, 5 and 6.

The conductor 1 first passes between a sheave 46 and a roller 47 of the first applying unit which will press the label against a slightly larger surface of the conductor.

The label is next engaged by spiral wiper 48 which is a metal strip adjusted to such length and so shaped that it will wipe the shorter projecting end of the label against the conductor 1 and cause its adherence thereto (Fig. 1b).

In the second applying unit the conductor passes between a sheave 49 and a roller 50 which guide it into engagement with a second spiral wiper 51, which, as shown in Fig. 1c, engages the other still projecting end of the label and wraps it partly around the conductor 1.

The label and conductor are guided to the third spiral wiper 54 by means of roller 52 and sheave 53. This third applying unit wipes, as shown in Fig. 1d, the projecting free end of the label completely around the conductor 1. The label is formed into a finished sleeve with its ends overlapping by the fourth spiral wiper 57 to which it is guided by sheave 55 and roller 56, and from there the conductor 1 is wound on the take-up drum 4.

The general construction of the four wipers is alike. The details of one are illustrated in Figs. 6 and 7. As here shown, sheave 53 is supported in a vertical position in brackets mounted on table 5. A spring 58, whose tension may be adjusted by a nut 59, provides a resilient seat for the sheave 53 whose horizontal position can furthermore be adjusted by means of a screw and nut arrangement 60 engaging the nose 61 projecting from the pivoted arm 62, the free end of which carries the sheave 53.

The spiral wiper 54 is mounted in a bracket 63 and its position is adjusted by means of vertical bolt 64 and horizontal spring 65 and adjustable nut 66 (Fig. 6). The roller 52 rotates on a shaft 67 extending out from a support attached to table 5.

It will thus be seen that the sheaves, rollers and spiral wipers are movable with respect to one another so that they will readily accommodate conductors of different diameters and cross-sectional shapes. It will be obvious from a study of the operation and of the drawing that other than round conductors 1, e. g. conductors that are practically flat or have some figure-eight cross-sectional shape, would be accommodated by the rollers, sheaves and wipers through which they pass, without any special adjustment of the machine or replacement of the parts. Also, the wipers are so arranged that the threading of a conductor therethrough can be readily accomplished by prying apart the rollers and sheaves, and placing the conductor sideways therebetween.

The labeling machine may be installed at any suitable assembly line position once the conductor has been tested, and it will form thereon, at spaced intervals, labels which encircle the conductor and which, furthermore, are so constructed that they cannot accidentally be removed in handling the conductor. The labels, being of pliable material, will not injure the insulation of the conductor.

It will be obvious to those skilled in the art that many modifications and adaptations are possible, without departing from the spirit of the in-

6

vention. For instance, the head of the machine which serves to sever the individual labels from the spool of web may be combined with a machine for applying the labels to other objects than conductors, whether the label is applied flat against the object or curved around the whole surface or a part thereof.

Also, the spacing between the knives 38 may be changed as well as the gear 18 and, thus, the length of label which is severed from the tape can be varied to meet any particular requirement. In practical machines, two, three or more cylinders 22, complete with knives 23 having different spacings as well as various sized gears 18, are supplied so that the machine can be readily changed as far as the length of label is concerned, to accommodate various diameters of wire.

What I claim is:

1. In a method of applying to a longitudinally moving conductor labels having a tacky side, the steps of pressing the tacky side of a label to the conductor with the ends of the label projecting, one longer than the other, folding the shorter end against the conductor in one direction, and then folding the longer end against the conductor in the opposite direction.

2. In a machine for applying to a conductor pieces of pressure sensitive tape, a roller aligned with the conductor for first sticking a piece of tape between the ends to the conductor, means for moving said piece between the roller and conductor, means for successively wiping the projecting label ends against the conductor comprising solid elements presenting surfaces in the paths of the projecting ends, and means for moving the conductor along said surfaces to form the label into a closed sleeve about the conductor.

3. In a machine for labeling conductors, the labels being on a coiled tape having a slick and a tacky side, means to move the conductor longitudinally through a central opening in the machine, a plurality of equally spaced knives, means for revolving said knives around said opening at a speed determined by the speed of movement of said conductor, a resilient roller mounted adjacent the path of said knives, means including said knives for unwinding the tape with the slick surface bearing against said roller so that a knife engaging said roller will carry the tape off the roller and sever it when successive portions of the knife edge make successive point contact as the tape is pressed against the hard surface of a resiliently mounted rotatable cylinder with the tacky side of the severed ends adhering to the two knives, a roller having a groove in alignment with the conductor, the knives being carried between the conductor and said roller, a cam for pressing said roller against the conductor when a severed length of tape is between the roller and conductor, said roller engaging the severed length at a point intermediate its ends but nearer one end, means for folding in one direction the shorter protruding end of the tape length against one side of the conductor, and means for folding in the opposite direction the longer protruding end of the severed tape length against the other side of the conductor.

4. A machine according to claim 2 and in which said solid elements are a plurality of spirally shaped wipers positioned adjacent the path travelled by the conductor.

5. In a method of applying pieces of pressure sensitive adhesive tape from a supply roll to a longitudinally moving conductor, the steps of

7

severing a piece of tape, carrying said piece into a position above and substantially parallel to the conductor, pressing the tape at a point between its ends to the conductor, and subjecting the tape to a plurality of successive wiping operations to press the free ends of the tape around the conductor.

6. In a machine for applying pieces of pressure sensitive tape from a supply roll to a moving object, a plurality of knives for removing the tape from the roll and severing it into pieces, means positioned above the object for pressing a piece of tape at a point between its ends onto the object, and wiper means for pressing the free ends of the tape against the object.

7. The machine according to claim 6 and in which said wiper means are spirally shaped solid elements adjacent the path travelled by the object.

8. In a machine for applying pressure sensitive adhesive tape from a supply roll to a conductor, a first means for moving the conductor with respect to the machine and the tape, second means for unwinding the tape and severing successive lengths therefrom, said conductor passing through said second means, means for applying a severed length with its tacky side against the conductor, and means controlled by said first means for operating all the other means by moving the conductor through said second means.

8

9. In a machine for applying pieces of pressure sensitive adhesive tape from a supply roll to round shaped conductors, a first means for unwinding the tape and severing successive lengths therefrom, a second means for pressing a severed length with its tacky side against the conductor at a point between the ends of the length, a third means for wiping a first protruding end of the tape length stuck to the conductor against one side of the conductor, and for wiping the other protruding end of the tape length stuck to the conductor against the said first end, and a fourth means controlling the operation of the first, second and third means by moving the conductor longitudinally with respect to the machine and the tape.

JAMES L. ENTWISTLE.

REFERENCES CITED

The following references are of record in the file of this patent:

UNITED STATES PATENTS

Number	Name	Date
1,547,373	Ermold	July 28, 1925
2,060,193	Gilson	Nov. 10, 1936
2,204,219	Jahne et al.	June 11, 1940
2,234,017	Bauer	Mar. 4, 1941
2,317,576	Avery	Apr. 27, 1943
2,346,142	Anderson	Apr. 11, 1944