

HISTORY

MARTIN CLIFFORD

In this, the first installment of our new, occasional series about the early days of radio, we look at the original "solid-state" receivers.

DID YOU KNOW: THAT SOLID-STATE ELECTRONICS can trace its roots back to 1835? That radio signals can be demodulated using sulfuric acid or nitric acid? That oil-filled variable capacitors were once used in radio receivers? That a single crystal detector can be used as a radio receiver? That there are some radio receivers that never need to be turned off, have no on/off switch, and do not require battery or AC power? Or that lenzite, zincite, bornite, tellurium, and chalcopyrite are all semiconductors?

Most of us believe that the age of solid-state electronics began with the invention of the transistor; Bardeen and Brattain of Bell Laboratories produced that first crystal triode in 1948. However, lost in the mists of history is the fact that true solid-state receivers have been with us since about 1918.

In more recent times, the term solid-state has been so firmly associated with germanium, and subsequently with silicon, that no one should be blamed for thinking that those are the only materials

The Early Days of RADIO

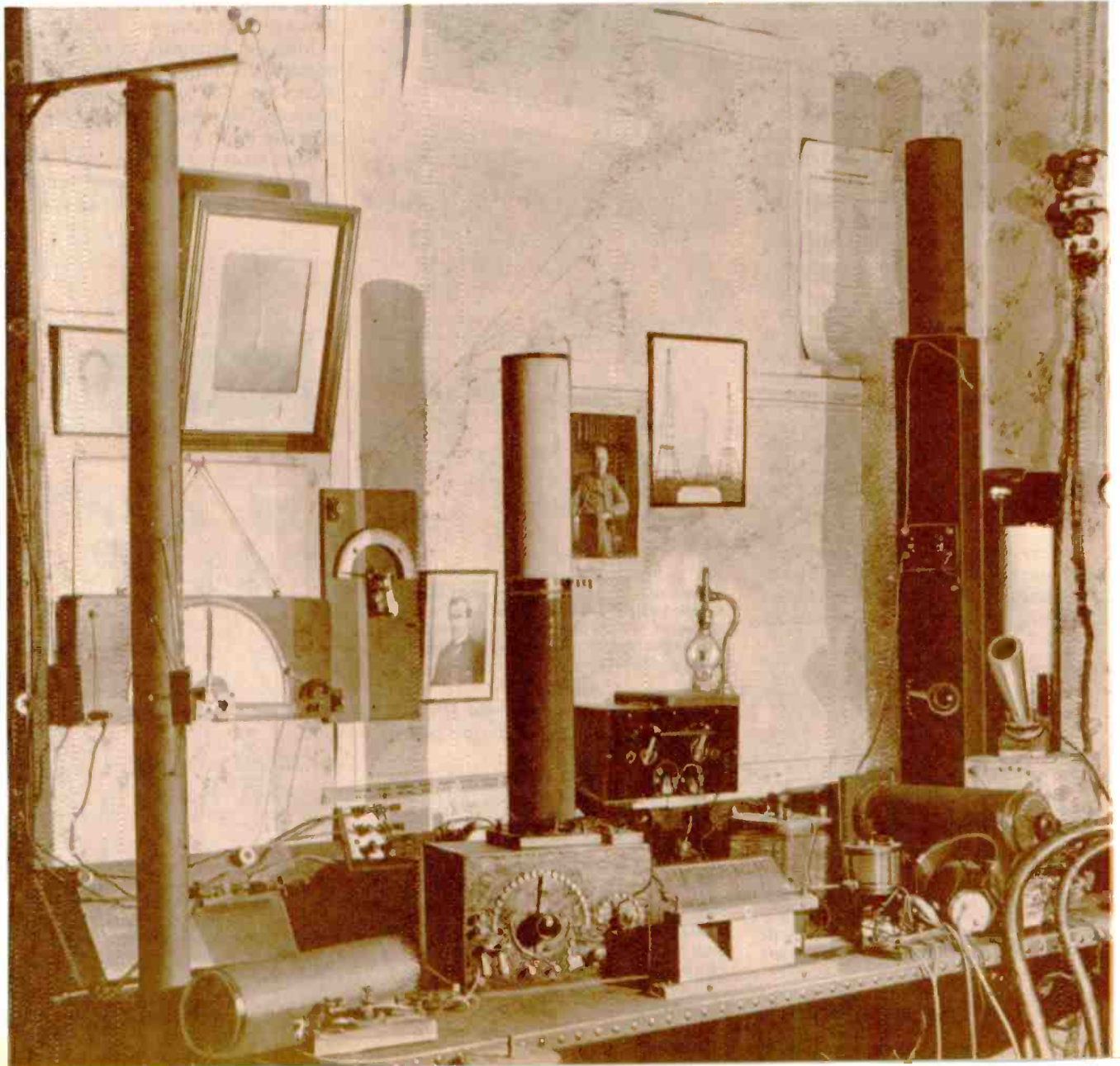

suitable for use in semiconductors. Yet there are numerous materials that are just as suitable. Among them are carborundum (silicon carbide); galena (a crystal sulphide of lead); molybdenum; lenzite; zincite (an oxide of zinc); tellurium; bornite (a sulphide of iron and copper); chalcocite (also known as copper pyrites); and cerusite. Except for carborundum, a manufactured material also used as an abrasive, all are materials that are found in nature.

Early solid state

The fact that certain materials have rectifying properties (that is, they allow current to flow in one direction only) has been known since 1835, thanks to the research of one Munk Af. Rosenshold. At the time a laboratory curiosity, his discovery was largely forgotten until it was unearthed again by F. Braun in 1874.

However, a practical use for that discovery was not found until many years later. It came at a time when interest in radio was heating up and many early experimenters had radio setups in their attic or basement workshops.

Rectifiers are key components in simple radio detectors. Along with vacuum tubes, early experimenters turned to solid-state rectifiers made from one of the substances that exhibit natural rectifying properties. Since most of those substances are crystalline in nature, such rectifiers were called *crystal detectors*; radios that used such detectors were called *crystal radio sets*, or simply crystal sets.

The simplest radio

Early vacuum-tube rectifiers, such as the UX-201A and UV-199 triodes, cost about \$15. Since \$15 a week was considered good pay for a workman back then, and since crystal detectors cost only a small part of that amount, many experimenters turned to crystal sets. Such radios were among the simplest possible, consisting of just a crystal detector and a headset. See Fig. 1.

The crystal set of Fig. 1 has its virtues, but it also has plenty of faults. Selectivity is non-existent; after all, that radio has no tuning circuits. So whatever the radio re-

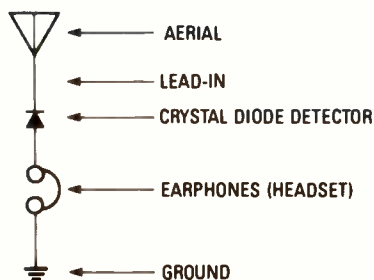

FIG. 1—THE SIMPLEST CRYSTAL RECEIVER consists of an antenna, a detector, headphones, and a ground.

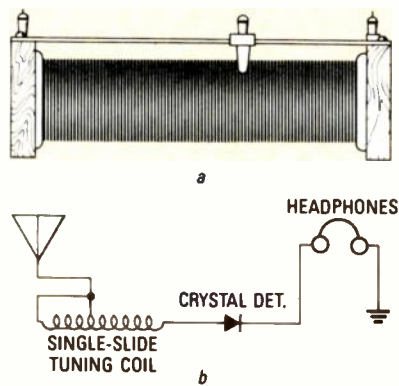

FIG. 2—TO IMPROVE SELECTIVITY a slide-tuned coil can be used (see a). The schematic of a crystal set that used such a coil is shown in b.

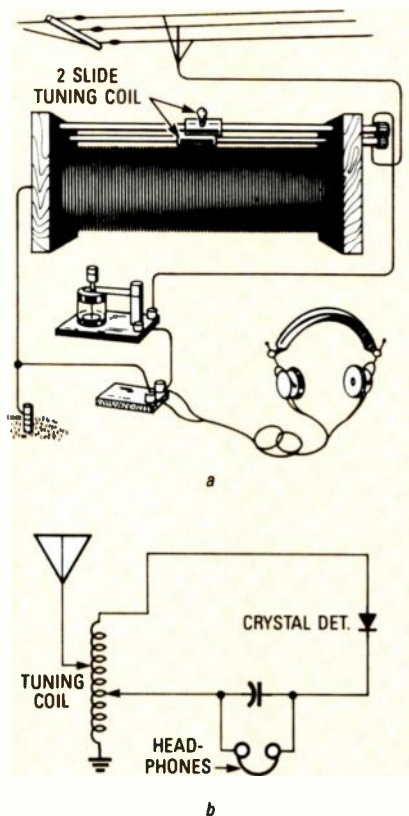

FIG. 3—FOR EVEN GREATER selectivity, receivers with double-slide-tuned coils were developed (a). The schematic of such a set is shown in b. Note the inclusion of a capacitor across the headphones. Its purpose was to bypass the RF carrier.

ceives is what you hear—the strongest signal dominates, and all the rest provide background noise.

The earliest effort at improving selectivity was to add a tuning coil like the one shown in Fig. 2-a. That coil consisted of enamel insulated wire wound on a round form; experimenters often used cylindrical oatmeal boxes as the coil form. The amount of inductance could be selected using a metal slider. The tuning method was crude, but the radio circuits that included that coil (see Fig. 2-b) did offer at

least some improvement over those with no tuning at all.

Another problem was that the output of the crystal detector consisted of both an audio signal and an RF carrier; both were passed directly to the headphones. Subsequently, a small capacitor was placed across the headphones to bypass the RF carrier.

Also, it was found that selectivity could be further improved by adding a second slider to the tuning coil. The radio shown in Fig. 3-a incorporates both those improvements; the schematic for that circuit is shown in Fig. 3-b.

Improved designs

As time went on, various methods were used to improve tuning. In one arrangement, shown in Fig. 4-a, the single-slide tuner was used as the primary of an RF transformer. The secondary winding, which was tapped, was wound on a form that could travel into the primary by means of a pair of rods. That resulted in triple tuning. The primary was tuned by the single slider; coupling was adjusted by moving the secondary in or out of the primary, and finally, the appropriate secondary tap could be switch selected by the operator. The schematic for the circuit is shown in Fig. 4-b.

Since most crystal radio receivers are "powered" by the radio signal itself, they require no voltage supply or battery. (They

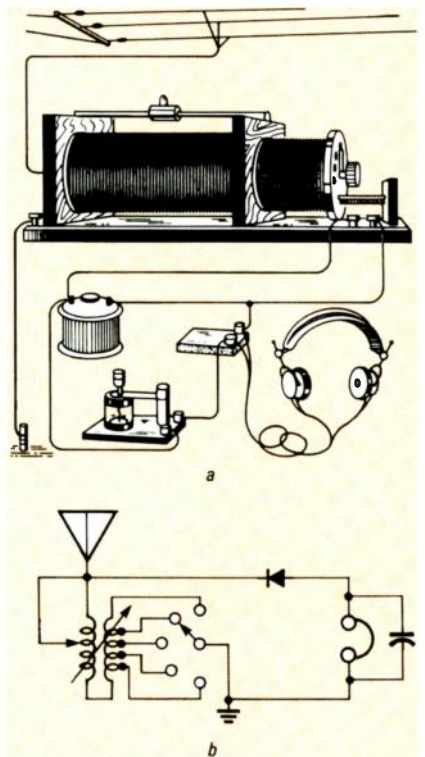

FIG. 4—IN THE CRYSTAL SET SHOWN in a the slide-tuned coil is used as the primary of an RF transformer; the secondary had multiple taps and was wound on a form that could be moved in to or out of the primary. The schematic of the circuit is shown in b.

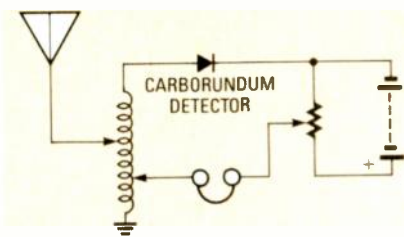

FIG. 5—BATTERY POWER was needed in crystal sets that used carborundum detectors.

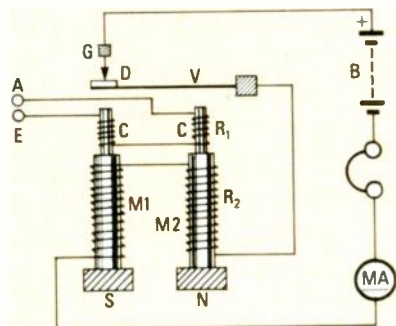

FIG. 6—BECAUSE OF THEIR LOW OUTPUT, some sort of amplification was often used with carborundum sets. Here, a popular mechanical amplifier of the time is shown.

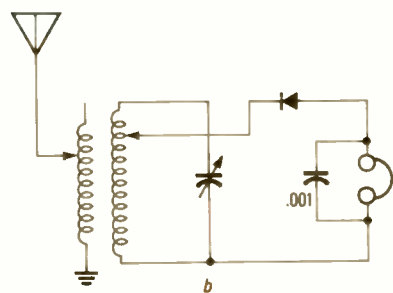
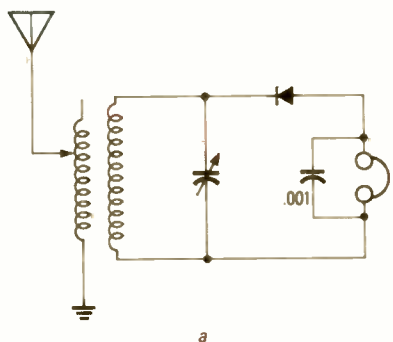

FIG. 7—THE SELECTIVITY OF CRYSTAL SETS was further improved by the addition of a variable capacitor. Here two designs, one (a) using a single-slide-tuned coil, the other (b) a double-slide-tuned coil, are shown.

also require no on/off switch.) However, that is not always the case.

One detector that was popular for a while was made from carborundum. As you can see in Fig. 5, a receiver design using that detector required a voltage source. Further, the output of the detector

was weak. Those two factors eventually caused the carborundum detector to fall out of favor, but not before it gave rise to some interesting circuit innovations.

One of those was the concept of the amplifier. The early amplifier shown in Fig. 6 was a mechanical one known as the Brown amplifying relay. The leads identified as A and B were connected to the output of the detector. The signal current through relay coil M₁ caused relay armature v to vibrate, thus varying the magnetic field around winding R₂ of the second relay. That caused the current supplied by the battery to be varied at an audio rate. That current flowed through the headphones, producing sound. In some instances a series arrangement was used; the current from the battery drove still another mechanical amplifier.

The need for clumsy tuning coils was finally eliminated through the use of a variable capacitor, then known as a condenser. For a while, however, variable capacitors were used in conjunction with single- and double-slider variable coils. Two examples of capacitor-coil-tuned circuits are shown in Fig. 7.

In some of the more advanced sets, a vario coupler, sometimes called a variometer (see Fig. 8), was used. That consisted of a pair of coils mounted in such a way that one could be rotated within the other.

Ordinarily, the variable capacitors used were air types; that is, the dielectric between the stator and rotor plates was air. Air, though, has a dielectric constant of 1. To increase the capacitance without adding more plates, one design had the variable capacitor positioned in a leak-proof, transparent case, filled with oil. Oil has a dielectric constant of five, so the capacitance of such a capacitor is five times that of one with an air dielectric (assuming all other variables to be the same). One such capacitor had 17 plates and a total maximum capacitance of 0.0004 μF , while another had 43 plates and a maximum capacitance of 0.001 μF .

Anyone who has had any contact with radio knows that the antenna plays an important role in determining the quality of the received signal. Antennas were even more important in the days of the crystal set. That's because that design made no provision for amplification. Thus, the strength of the signal heard was wholly dependent on the strength of the signal delivered by the antenna. Some of the schemes devised were quite elaborate; others were quite simple. For apartment dwellers, a bedspring was a popular alternative to an outdoor design; the ground connection was made to a cold-water or radiator pipe.

The crystal detector

So far, we've spoken about how crystal detectors were used in early radios. But

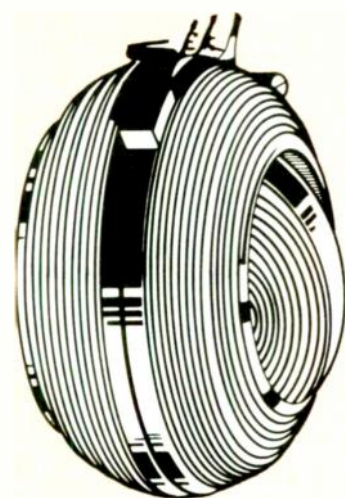

FIG. 8—A VARIO-COUPLER, or variometer, consisted of two coils mounted in such a way that one could be rotated within the other.

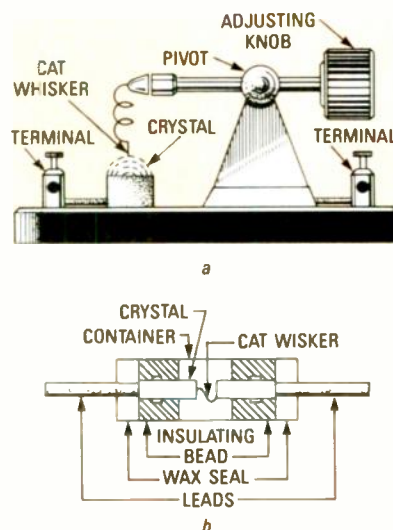

FIG. 9—TWO CATWHISKER DETECTORS. A variable contact type is shown in a; a sealed, fixed unit is shown in b.

we've not looked at the detector itself and how it was made. It is time now to correct that oversight.

Crystal detectors were available in two basic forms: contact and combination. Of those, the contact detector was cheaper and more popular.

A single crystalline substance was used in the contact detector. A small bit of spring wire, called a *catwhisker*, was placed so that it made contact with a point on the crystal. In early detectors, the catwhisker was designed to be variable because finding the most sensitive spot on the crystal was a trial-and-error procedure. See Fig. 9-a.

The catwhisker was usually made from stiff phosphor bronze, but in more expensive detectors silver or 18-karat gold was used. The wire was coiled, with a small straight extension ending in a blunt point—an arrangement much like that

used in the first point-contact transistors many years later. There were two connections to the crystal detector: one to the catwhisker and another to the cup holding the crystal.

Later on, fixed-position catwhiskers in sealed containers became available. See Fig. 9-b.

The combination crystal detector consisted of two different crystals in close contact. Various combinations of minerals were tried, including bornite and either zincite or copper pyrites. Another combination detector used tellurium and

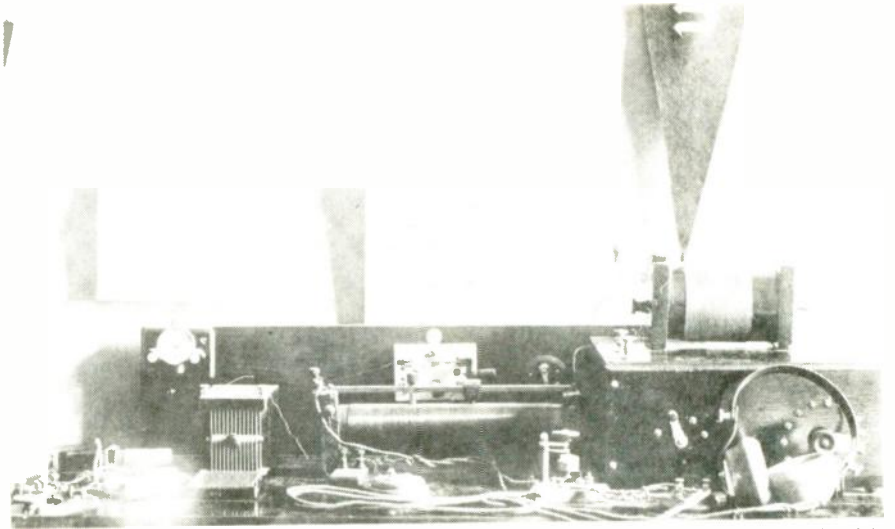

AN EARLY WIRELESS RECEIVER. With this set-up, which was part of amateur station 1-WP, Warwick, RI, circa 1913, the operator was able to log stations from Maine to Florida. Note the variable-contact catwhisker crystal detector, 23-plate tuning capacitor, and double-slide-tuned coil.

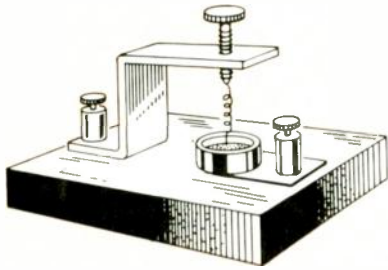

a

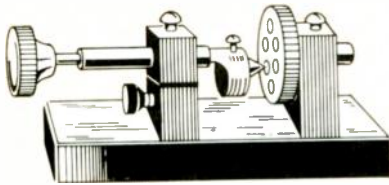

b

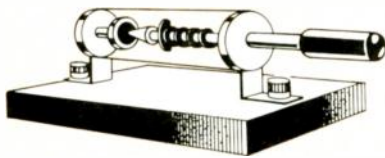

c



d

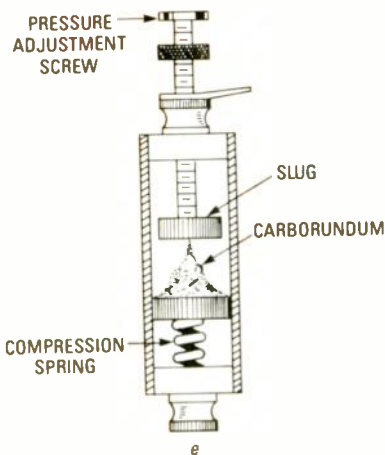

e

FIG. 10—FIVE POPULAR DETECTORS: Variable-contact catwhisker (a), Perikon (b), combination crystal (c), fixed-contact catwhisker (d), and carborundum (e).

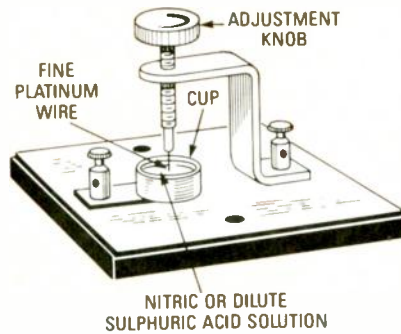

FIG. 11—IN AN ELECTROLYTIC DETECTOR the rectifying material was nitric acid or diluted sulphuric acid.

chalcopyrite (copper pyrites). The chief advantage of the combination detector was that it was less susceptible to vibration than the catwhisker type.

Some of the many different types of crystal detectors are shown in Fig. 10. We've so far looked at all of those save one—the Perikon detector, invented by Pickard in 1906, and shown in Fig. 10-b. That detector used a small, cone-shaped piece of zincite. The zincite could be positioned so that it contacted one of several segments of chalcopyrite located on a circular plate. By selecting which segment of chalcopyrite was used, the detector could be "tuned."

As we stated earlier, most detectors were made using a crystalline material. However, "most" is not "all." One detector that was at least briefly popular was the electrolytic detector, shown in Fig. 11. The design of that detector was similar to that of the catwhisker, but nitric acid, or a dilute solution of sulphuric acid, was used in place of the crystal. Despite that detector's high sensitivity, it had disadvantages. One was that the wire tended to curl away from the acid—so the wire fre-

quently had to be repositioned or replaced. Secondly, the detector used exposed acid, which is dangerous.

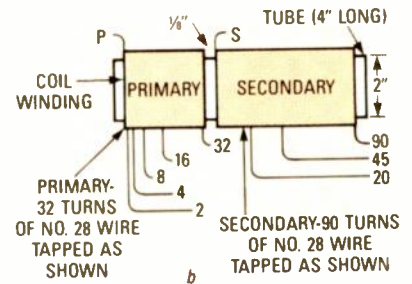
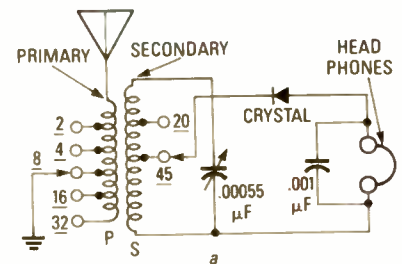

FIG. 12—YOU CAN BUILD this crystal set (a) using modern components. Winding details for the coil are shown in b.

Building your own

We hope this article has aroused your interest in the electronics of days gone by. If you want to recapture some of the flavor of the early experimenters, perhaps you'd like to try building your own crystal receiver. If so, the circuit shown in Fig. 12-a can be built using modern parts.

In that circuit we've replaced the slide-tuned coil with a tapped one. (Finding a slide-tuned coil these days would be nearly impossible.) Full details of the coil are given in Fig 12-b. Just about any diode can be used for the detector. For best results, plan on using an outdoor antenna that's at least 75 feet long.

R-E